

**OLYMPUS**<sup>®</sup>

Your Vision, Our Future

Inverted Microscope

**CKX41/CKX31**

**UIS2**  
World-leading optics

*A New Advance in Routine Inspections*





## **Incorporation of advanced UIS2 optics ensures excellent clarity for cell checking applications.**

CKX series microscopes make cell checking quicker and easier than ever—because they are simple to operate, require minimal optical adjustments and capture superb observation images with outstanding efficiency.

Use of a tilting observation tube, which allows the user to make observations while standing, is an especially convenient feature.

In addition, the compact design allows installation right beside the incubator, improving safety and saving time spent on carrying specimens elsewhere for observation.

Multiple observation methods are supported, and the range of applications has been further increased.

The CKX series: designed to make routine cell checking quicker, easier and more efficient.



### **CKX31**

Standard microscope for cell culture observation with fixed binocular tube.

### **CKX41**

A binocular tilting tube, which allows observation while standing, and a trinocular observation tube which is compatible with various video cameras are available. Numerous accessories make it easy to upgrade the CKX41 according to need.

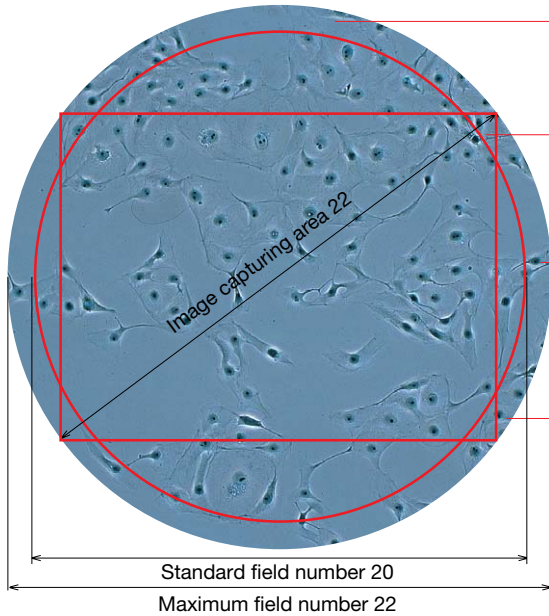
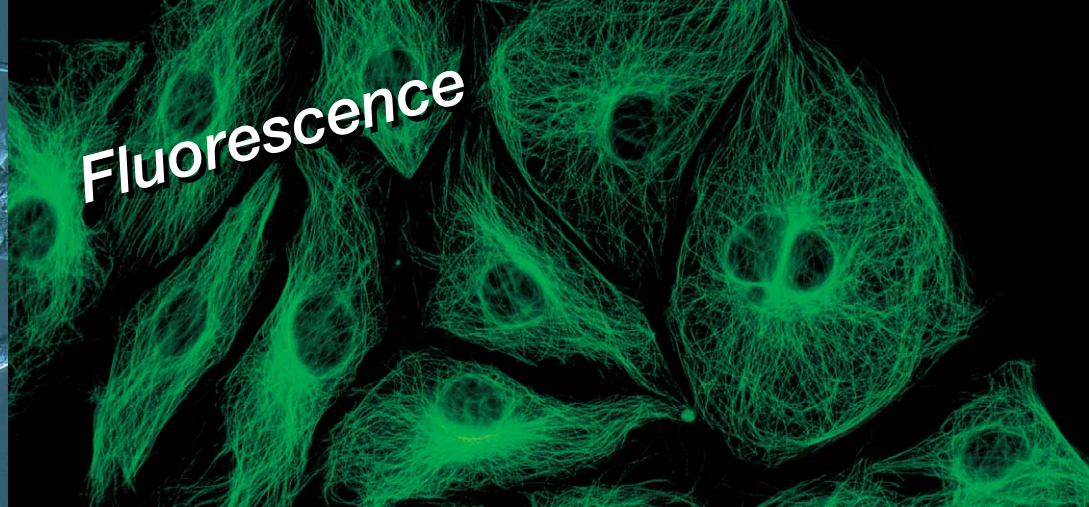
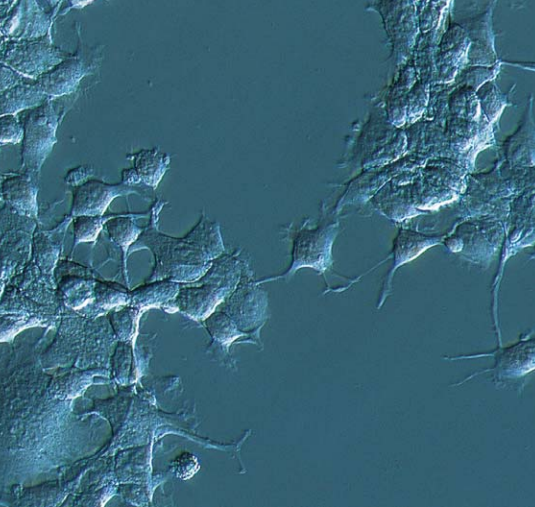

**Clear, wide-ranging phase contrast observation.  
Ideal phase plate for cell culture.**

**Clear cell observation right to the edge of the container.  
PHC objective virtually unaffected by surface tension.**

**Low magnification UIS2 video adapters can be used for  
0.25x, 0.35x, 0.5x and 0.63x magnifications, enabling  
clear display of the complete cell on the monitor.**

**Clear up to the edge of the view field.  
Flatness improved for 10 to 15%**

### The UIS2 optics provide high optical performance

The UIS2 optical system combines the simplicity of the light path and the imaging excellence of a relay lenses to maintain excellent image intensity and to achieve an exceptional level of optical correction. Thanks to this feature, the UIS2 infinity-corrected optical system delivers high resolution and contrast. In addition to improved image quality, the maximum field of view has been extended to FN 22. This allows the use of various observation tubes provided for upright microscopes (patented, CKX41 only).

### Enhanced clarity makes it easier to observe cell activity status

Incorporation of the world-renowned Olympus UIS2 optical system in the CKX series makes a dramatic improvement in flatness for 10 to 15% and enables very clear, high contrast images to be obtained up to the edge of the field view.

### Adoption of a UIS2 phase plate optimized for cell culture observation provides higher image contrast

The UIS2 phase plate adjusts the contrast according to the thickness of the cell culture, producing higher contrast images than those obtainable from conventional systems.

### PHC type objectives minimally affected by surface tension around the container edge (CPLN10×PH, CPLFLN10×PH, LCACHN20×PH)

The PHC type objectives are minimally affected by surface tension of the culture fluid, which can compromise clarity at the image periphery. Easier multi-well observation is one of several benefits. Combined with the improved flatness resulting from the use of UIS2 optics, this feature facilitates clear observation of cells even at the edge of the container.

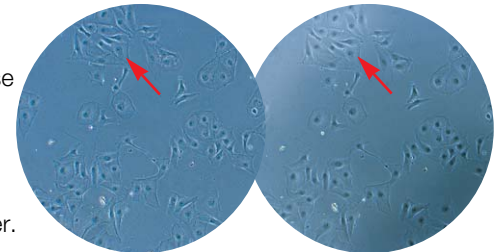

PHC objective

Standard objective

### UIS2 infinity-corrected optical system

The advanced Olympus UIS2 optical system maximized the advantages of infinity correction. Light travels through the body tube as parallel rays as it passes through the objective. These are focused by the tube lens to form a completely aberration-free intermediate image. Attachments can be added between the objective and the built-in tube lens in the observation tube without any magnification factor alterations to total magnification. Additional correction lenses are not required. The UIS2 optical system delivers optimum image quality with any configuration.

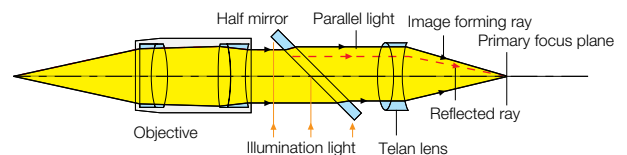



# Relief contrast observations

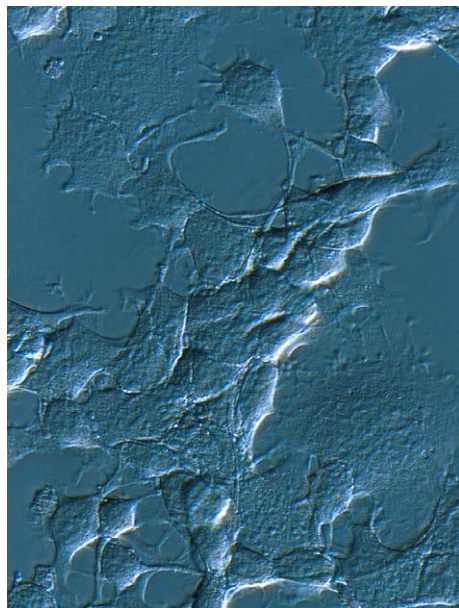

## High-resolution relief contrast with NA0.5: thick specimens like egg cells can be observed in three dimensions

Olympus' relief contrast maintains the same shadow direction even if the magnification is changed. The two-stage exchange slider uses a common aperture for 20x and 40x magnifications, so exchange between 10x/20x and 10x/40x is performed quickly. The same feature enables easy optical adjustment: by simply using the lever, the contrast can be changed while centering is being performed.



## Vertical installation avoids interference with manipulators

Vertical installation helps the user to avoid accidentally touching the manipulators while operating the slider or making optical adjustments.

# Fluorescence observations

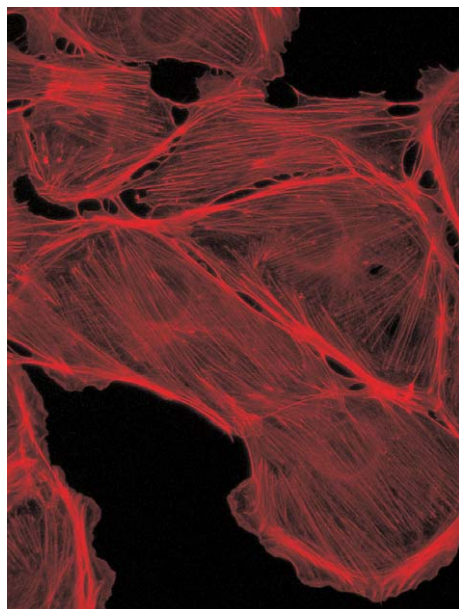

## Fluorescence observation system with tree-position allows the use of U excitation.

Adopted renowned UIS2 optics, this system provides B and G excitations and optionally U excitation as well. All three can be provided simultaneously, with quick, easy exchange among them. Many different UIS2 filters can also be installed, according to requirements, enabling this system to meet a wide range of fluorescence observations needs. Also, thanks to newly developed fluorescent illuminator, which secured UV transmission rate, and a variety of UIS2 fluorescent objectives, clear and high contrast fluorescent images are provided.



# Accessories

## Suitable for hemacytometer holder and other kinds of micro-plate

The mechanical stage offers excellent inspection performance with hemacytometer holders or other micro-plates.



## Glass stage insert plate and warm plate

Also included are a glass stage insert plate, for simple confirmation of the objective in use, and a warm plate for easy temperature control (CKX41 only).



# ***Just set the specimen on the stage and observe immediately while standing, with no optical adjustments.***

## **Pre-centered phase contrast slider for quick, adjustment-free observation**

With the pre-centered phase contrast slider, there is no need to repeat centering each time the objective magnification is changed. Likewise, ring slit exchange when swapping between objectives is also unnecessary, since the ring slit is standardized for 10x, 20x and 40x magnifications. The CKX series makes phase contrast observations quick and easy, without optical adjustments, for much more efficient performance of routine tasks. Since the phase plate transmission rates are dictated by the objective in use, the brightness remains constant even when the magnification is changed.

\*The IX2-SL with centering mechanism enables maximized phase contrast performance with precise optical adjustments.

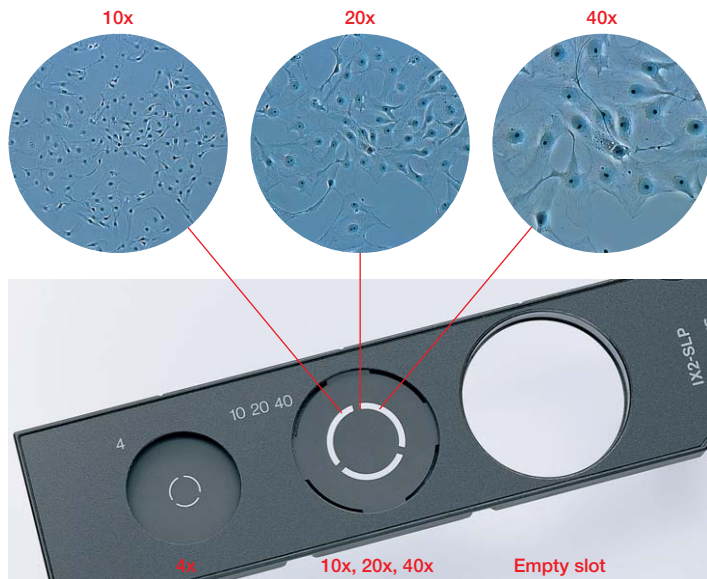

## **Slim, compact design takes up minimum laboratory space**

The slim, compact design minimizes the depth of the microscope, allowing easy installation right beside the incubator or clean bench. Specimens can be taken and immediately set on the microscope stage for quick, efficient inspection.



## **Tilting binocular tube for observation while standing**

The binocular tube has a 30–60 degree tilting mechanism to let the researcher make observations while standing. The specimen is removed from the incubator and placed straight onto the microscope stage, so that cell checking can be done immediately. "Quick observation, quick return"—that's the new style of routine inspection made possible by Olympus.



## **Easy observation at the clean bench**

The tilting binocular tube combination makes it unnecessary for researchers to adopt uncomfortable postures like lowering their face to the inside of the clean bench. Simply observe down the tube while working, and raise the tube afterwards: this method is much more convenient, since the clean bench can be opened/closed without moving the microscope.



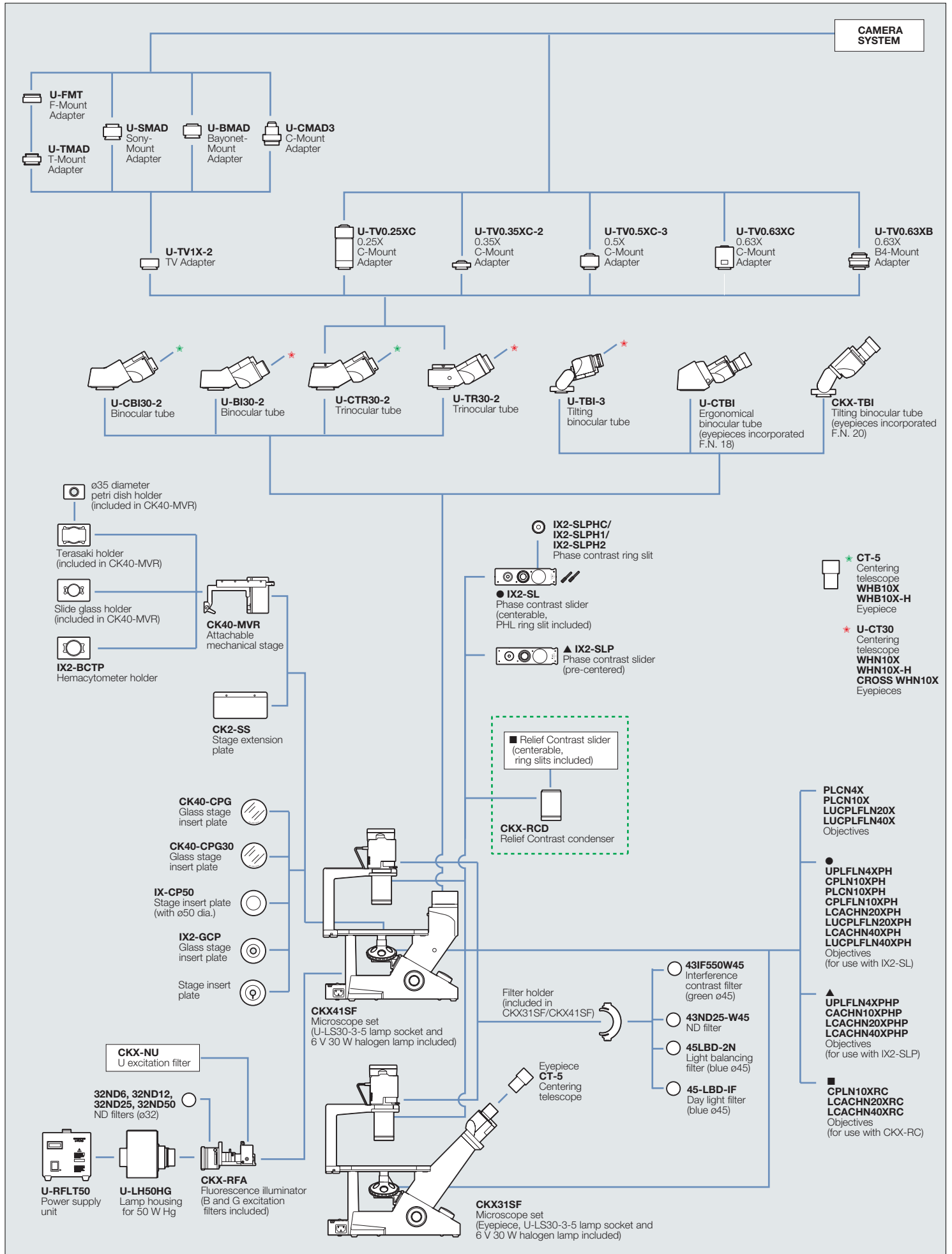

**CKX41/CKX31 specifications**

Item	CKX41	CKX31
Optical system	UIS2 (Universal Infinity-corrected) optical system	
Focus	Vertical nosepiece movement (stage is fixed), coaxial coarse and fine focus with tension adjustment mechanism, roller slide mechanism, stroke: 7 mm up and 2 mm down from focus position which is 1 mm above the stage, stroke per rotation: 36.8 mm (coarse), 0.2 mm (fine)	
Revolving nosepiece	Quadruple	
Stage	Plain stage	160 mm (L) x 250 mm (W) Exchangeable insert plate (ø25 mm opening) incorporated
	Mechanical stage	Right-hand low drive coaxial controls, stage movement: X=120 mm, Y=78 mm, with three dish/sample holders
	Substage	70 (L) X180 (W) mm ø35 petri dish holder stage incorporated
Illumination system	Light source	6 V, 30 W halogen lamp, lamp socket (U-LS30-3-5), built-in frosted and heat absorbing filters, detachable illuminator
	Filter holder	Insert up to 11 mm thick with ø45 mm filter, detachable
	Aperture diaphragm	Lever type, range: from minimum ø3 mm to maximum ø44 mm
	Slider insertion	With phase slider pocket and built-in slider position click stop mechanism
Condenser	Detachabale ultra-long working distance condenser (N.A. 0.3, W.D. 72 mm)	
Contrast slider	<ul style="list-style-type: none"> <li>•Pre-centered phase contrast: 4X, 10X/20X/40X, empty slot</li> <li>•Centerable phase contrast: 4X, 10X/20X, empty slot (40X optional, pre-centered)</li> <li>•Centerable for Relief Contrast: 10X, 20X, 40X</li> </ul>	
Observation tube	Binocular tube	U-CB130-2: inclined 30°, interpupillary distance range: 48-75 mm, diopter adjustment by helicoid on left sleeve (F.N. 20) U-B130-2: inclined 30°, interpupillary distance range: 48-75 mm, diopter adjustment by helicoid on left sleeve (F.N. 22)
	Trinocular tube	U-CTR30-2: inclined 30°, ring dovetail attachment, interpupillary distance range: 48-75 mm, tube length and diopter adjustment by helicoid on left sleeve Observation optical path: 50(binocular)/50(video port) (F.N. 20) U-TR30-2: inclined 30°, ring dovetail attachment, interpupillary distance range: 48-75 mm, tube length and diopter adjustment by helicoid on left sleeve Observation optical path: 50(binocular)/50(video port) (F.N. 22)
	Tilting binocular tube	CKX-TBI: variable inclination angles from 30° to 60°, interpupillary distance range: 50-76 mm, diopter adjustment by helicoid on right sleeve (F.N. 20) U-CTBI: variable inclination angles from 30° to 60°, interpupillary distance range: 48-75 mm, diopter adjustment by helicoid on right sleeve (F.N. 18)
		U-TBI-3: variable inclination angles from 5° to 35°, circular mounting dovetail attachment, interpupillary distance range: 50-76 mm, diopter adjustment by helicoid on right sleeve. (F.N. 22)
Fluorescent illuminator	Detachabale illuminator, switchable slide (3-position: B excitation, G excitation, empty slot or U excitation)	
Eyepiece	FL light source FL light shutter FL field stop FL cubes Filter	50 W Hg Available Available 2 cubes (B & G), option U (cubes are not compatible with UIS2). Filter and dichroic mirror size are same as UIS2 1 filter
		For U-CB130-2/U-CTR30-2/CKX-TBI: WHB10X/WHB10X-H (F.N. 20) For U-B130-2/U-TR30-2/U-TBI-3: WHN10x/WHN10x-H/ CROSS WHN10x (F.N. 22) For U-CTBI: (F.N. 18)
Power supply	Continuous intensity adjustment, built-in voltage changeover switch (100/120 V, 220/240 V), frequency 50/60 Hz	

**UIS2 objectives \*1 specifications**

	Objective	N.A.	W.D.(mm)	Remarks
For brightfield	PLCN4X	0.10	18.5	
	PLCN10X	0.25	10.6	
	LUCPLFLN20X	0.45	6.6-7.8	
	LUCPLFLN40X	0.60	2.7-4	
For phase contrast	UPLFLN4XPH	0.13	16.4	PHL (for use with IX2-SL)
	CPLN10XPH	0.25	10	PHC (for use with IX2-SL)
	PLCN10XPH	0.25	10.6	PH1 (for use with IX2-SL)
	CPLFLN10XPH	0.3	9.5	PHC (for use with IX2-SL)
	LCACHN20XPH	0.40	3.2	PHC (for use with IX2-SL)
	LUCPLFLN20XPH	0.45	6.6-7.8	PH1 (for use with IX2-SL)
	LCACHN40XPH	0.55	2.2	PH2 (for use with IX2-SL)
	LUCPLFLN40XPH	0.6	3.0-4.2	PH2 (for use with IX2-SL)
	UPLFLN4XPH <sup>*2</sup>	0.13	16.4	For use with IX2-SLP
	CACHN10XPH <sup>*2</sup>	0.25	8.8	For use with IX2-SLP
For RC	LCACHN20XPH <sup>*2</sup>	0.40	3.2	For use with IX2-SLP
	LCACHN40XPH <sup>*2</sup>	0.55	2.2	For use with IX2-SLP
	CPLN10XRC	0.25	9.7	For use with CKX-RC
For FC	LCACHN20XRC	0.4	2.8	For use with CKX-RC
	LCACHN40XRC	0.55	1.9	For use with CKX-RC
For FL	UPLFLN4X	0.13	17	U,B,G
	UPLFLN10X2	0.3	10	U,B,G
	UPLFLN20X	0.5	2.1	U,B,G
	LUCPLFLN20X	0.45	6.6-7.8	U,B,G
	LUCPLFLN40X	0.6	2.7-4.0	U,B,G

\*1 Objective lenses are lead free.  
\*2 Pre-centering objective

**CKX41/CKX31 dimensions**

(unit: mm)

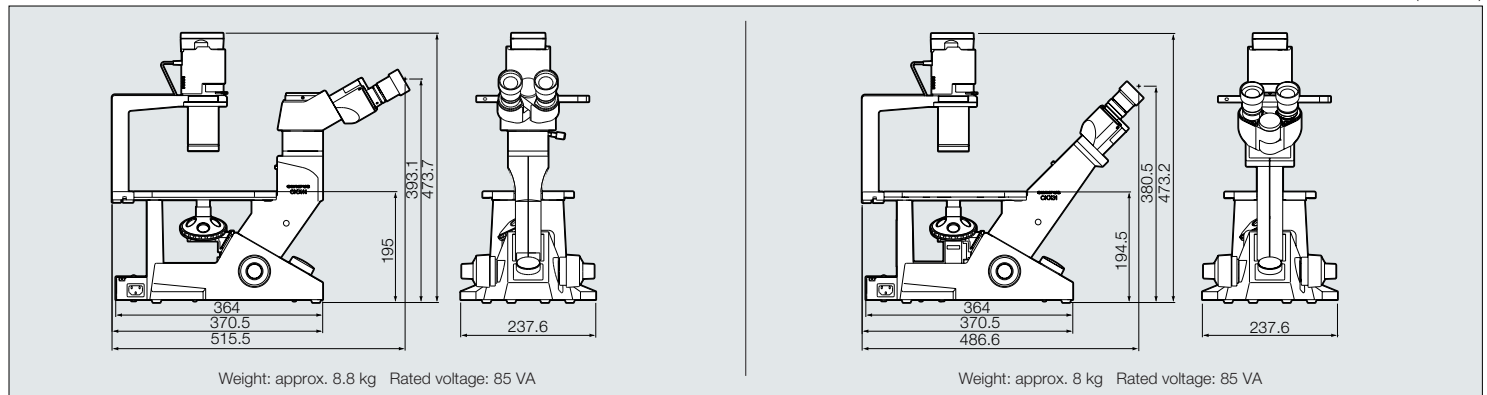

- OLYMPUS CORPORATION is ISO14001 certified.
- OLYMPUS CORPORATION is FM553994/ISO9001 certified.
- OLYMPUS CORPORATION is MD540624/ISO13485 certified.
- Illumination devices for microscope have suggested lifetimes. Periodic inspections are required. Please visit our website for details.

• All company and product names are registered trademarks and/or trademarks of their respective owners.  
• Specifications and appearances are subject to change without any notice or obligation on the part of the manufacturer.

[www.olympus-lifescience.com](http://www.olympus-lifescience.com)



For enquiries - contact  
[www.olympus-lifescience.com/contact-us](http://www.olympus-lifescience.com/contact-us)

**OLYMPUS CORPORATION**  
Shinjuku Monolith, 2-3-1 Nishi-Shinjuku, Shinjuku-ku, Tokyo 163-0914, Japan  
**OLYMPUS EUROPA SE & CO. KG**  
Wendenstrasse 14-18, 20097 Hamburg, Germany  
**OLYMPUS SCIENTIFIC SOLUTIONS AMERICAS CORP.**  
48 Woerd Avenue, Waltham, MA 02453, U.S.A.  
**OLYMPUS SINGAPORE PTE LTD.**  
491B River Valley Road, #12-01/04 Valley Point Office Tower, Singapore 248373  
**OLYMPUS AUSTRALIA PTY. LTD.**  
3 Acacia Place, Notting Hill VIC 3168, Australia

**OLYMPUS LATIN AMERICA, INC.**  
5301 Blue Lagoon Drive, Suite 290 Miami, FL 33126, U.S.A.  
**OLYMPUS (CHINA) CO., LTD.**  
ABF, Ping An International Financial Center, No. 1-3, Xinyuan South Road, Chaoyang District, Beijing, 100027 P.R.C.  
**OLYMPUS KOREA CO., LTD.**  
8F Olympus Tower, 446 Bongseunsa-ro, Gangnam-gu, Seoul, 135-509 Korea